



SPE

A Better World WASHED by Oil: Are You Significant or Just Successful?

L. Stuebinger, Fires for Him, Inc.

Copyright 2007, Society of Petroleum Engineers

This paper was prepared for presentation at the 2007 SPE Annual Technical Conference and Exhibition held in Anaheim, California, U.S.A., 11–14 November 2007.

This paper was selected for presentation by an SPE Program Committee following review of information contained in an abstract submitted by the author(s). Contents of the paper, as presented, have not been reviewed by the Society of Petroleum Engineers and are subject to correction by the author(s). The material, as presented, does not necessarily reflect any position of the Society of Petroleum Engineers, its officers, or members. Papers presented at SPE meetings are subject to publication review by Editorial Committees of the Society of Petroleum Engineers. Electronic reproduction, distribution, or storage of any part of this paper for commercial purposes without the written consent of the Society of Petroleum Engineers is prohibited. Permission to reproduce in print is restricted to an abstract of not more than 300 words; illustrations may not be copied. The abstract must contain conspicuous acknowledgment of where and by whom the paper was presented. Write Librarian, SPE, P.O. Box 833836, Richardson, Texas 75083-3836 U.S.A., fax 01-972-952-9435.

Abstract:

The oil industry has failed to change its public image of greed because we have had no focused, coordinated program to show that we genuinely want to make the world a better place for mankind. Leveraging oil industry skills like drilling, pump repair, and water filtration to provide WASHED programs (safe **W**ater, **S**anitation, **H**ygiene, **E**ducation, and **D**evelopment) could change that. Lessons from four trips to developing countries are discussed. We can leave no greater legacy than literally saving children's lives by helping them to have a better, healthier future.

Introduction

For over a century, the oil industry has had a bad public image. In July 2007, the *Financial Times* reported that in a recent Gallup poll of various US industry sectors, the oil industry came in last with the poorest rating of any industry since the poll began¹.

Success is a word that is about achieving self-serving goals, but significance is about helping others to succeed. One probable reason for this is that our industry has failed to have a focused effort to demonstrate that we care about mankind and our planet. Porter and Kramer state in the Harvard Business Review that corporations should tie social responsibility prospects within the same framework that guides their core business². A large scale, coordinated program to provide safe water using skills readily associated with our industry (like drilling and pump repair) could accomplish that. Additionally, coupling inexpensive hygiene and sanitation training programs with water programs could counter our negative environmental image. This would be a logical response to SPE President Abdul-Jaleel Al-Khalifa's challenge to petroleum engineers to fulfill our greater purpose and to our industry to demonstrate social responsibility³.

This paper discusses a potential win-win-win situation for

engineers, companies, and the impoverished. Lessons learned from a petroleum engineer's four trips with an organization named Lifewater International (Lifewater) to equip indigenous teams to sustain WASHED projects in their communities are discussed. Engineers who recognize they have an even greater purpose in this world than providing affordable energy will be rewarded immensely if they respond to our president's challenge. These engineers will transcend personal success by becoming "significant."

Image Makeovers: from "Successful" to "Significant"

John Rockefeller and Bill Gates successfully developed commanding control of their respective industries. The public strongly believed each of them to be ruthlessly manipulating market price of their products. John Rockefeller's monopolistic control of the oil industry was broken by the Sherman Antitrust Act and his image as a successful, but ruthless businessman continues to this day. In contrast to that, the Bill and Melinda Gates Foundation is a well-publicized, focused effort that shows Bill Gates really does want to help less fortunate people. His significance to mankind will surpass his success in business.

Bill Clinton's campaign to become the 42nd president of the United States was an overwhelming success. Although he left office in disgrace from a scandal, the Clinton Foundation has made him a very popular man once again. It was very evident in sub-Saharan Africa that his efforts were appreciated. Like Gates, Clinton has attained significance in the eyes of the public. He has shown that he cares about people.

Gates and Clinton have redirected much of the public's attention from their personal successes to their significance in the lives of those in need. The oil industry could learn from these examples to successfully make over its image. Engardio quotes the CEO of Unilever as saying "...helping such nations wrestle with poverty, water scarcity, and the effects of climate change is vital to staying competitive in coming decades⁴." A focused, well-publicized effort to employ oil industry strengths to help the poor could divert some public attention from our business success to our significance to mankind. Partnering numerous WASH Non Governmental Organizations (NGOs) could maximize that exposure.

Our World in Need

Medilynx is an organization that attempts to provide medical and public health information concerning Africa-related fields. Their website presents some disturbing issues⁵.

- Half the world's hospital beds are occupied by people suffering from waterborne diseases.
- Within 25 years, half the world's population could have trouble finding enough freshwater for drinking and irrigation.
- Two hundred scientists in 50 countries have identified water shortage as one of the two most worrying problems for the new millennium. (The other was climate change.)
- Currently, over 80 countries, representing 40 per cent of the world's people, are subject to serious water shortages. Conditions may get worse in the next 50 years as populations grow and as global warming disrupts rainfall patterns.
- Water-borne diseases are responsible for 80 per cent of illnesses and deaths in the developing world, killing a child every fifteen seconds.
- Those without access to adequate sanitation are the poorest and most vulnerable. The problem is particularly severe in remote rural and rapidly growing urban areas.
- In Africa, 300 million people—40 per cent of the population—live without basic sanitation and hygiene, an increase of 70 million since 1990

WASHED

Definition. Water, Sanitation, Hygiene, Education and Development (WASHED) programs are critically needed in the developing world. NGOs and governmental organizations like UNICEF have been struggling for decades to assist the multitudes of people around the world who are victims of unsafe water, sanitation, and hygiene.

Safe drinking water projects alone are not sufficient to substantially improve the health of communities. Hygiene and sanitation training and promotion are inexpensive but essential companions to a safe water program. Hygiene and sanitation block disease paths and thereby reduce disease. The BBC News reports that the British Medical Journal conducted a poll that found "The development of sanitation has been the greatest medical advance in the last 166 years..."⁶

In their efforts to provide safe drinking water, NGOs like Lifewater discovered that safe drinking water is only one part of the problem. Use of filthy water containers and failure to wash hands (hygiene) after defecating are just two reasons why safe water programs are ineffective without accompanying hygiene and sanitation promotion. Failure to employ basic sanitation concepts is a major reason that rivers and other water sources are badly contaminated. Hygiene training is necessary to teach people the importance of hand washing and proper food handling to block disease paths. Proper sanitation (human waste and garbage disposal) not only blocks disease paths, but preserves safe water sources and reduces contamination. Expanding safe water projects to include sanitation and hygiene is not costly. WaterAid estimates that "projects providing safe water, sanitation and hygiene education cost just £15 per head"⁷.

WASH plus Education and Development. WASH (Water, Sanitation, and Hygiene) is a commonly used acronym, but it

lacks two important elements of a successful program that Lifewater www.Lifewater.org has determined to be essential. Unless people learn the importance of the WASH components through Education and promotion, they will not embrace healthy habits. Unless communities Develop means to sustain and improve healthy conditions rather than depend on outside help, they will eventually regress.

Most people will instinctively prefer to drink safe water. However, it is not obvious to the uneducated that it is worth protecting water supplies and even using a precious resource like clean water to wash. Educating people and promoting healthy habits are crucial elements of any sustainable improvement program because people will not change their habits if they don't realize they have a problem.

Many NGOs have also learned that it is important to avoid creating community dependency. Relief efforts, as in the case of a natural disaster, have an important place in the world, but relief in the absence of a disaster can create dependency. Programs that train indigenous people to carry on the work are more cost effective and more sustainable. Thus Water, Sanitation, and Hygiene, Education and Development (WASHED) is the necessary response.

WASHED Addresses All Eight UN Millennium Goals

In September 2000, the United Nations established eight goals⁸ to be achieved by 2015. Reliability engineering teaches that it is more efficient to prevent problems by correcting root causes than to fix recurring symptoms of the real problem. An industry-sponsored WASHED focus could be unique because it could correct a root cause for each of the eight problems targeted by the UN. Brief descriptions of those eight goals follow along with a description of how WASHED programs could correct some of the root causes of each particular goal.

1. Eradicate Extreme Hunger and Poverty. Seventy-four countries (1/3 of the world's population) are not on track to meet this goal. People who are ill from waterborne diseases, inadequate sanitation, or poor hygiene are not as productive as when they are healthy. Healthier, better educated children can improve their families' income and help their families and communities with WASH training learned at school. Further, irrigation or hand watering is often necessary in many regions for better crop yields. Sicknesses caused by unsafe water also disrupt the body's ability to absorb nutrients, compounding the effects of hunger and malnourishment.

2. Achieve Universal Primary Education. WASHED programs could help improve education because children are unable to attend school when ill or collecting water from distant sources. Waterborne diseases are the most frequent cause of illness in young children in many parts of the world. Female children are often unable to attend school after puberty when latrines are not provided. Education is critical to improving health and welfare.

3. Promote Gender Equality and Empower Women. The UN states that women work two-thirds of the world's working hours, produce half of the world's food, and yet earn only 10%

of the world's income and own less than 1% of the world's property according to the UN. Since women and girls have the primary burden of collecting water in many countries, WASHED programs would help alleviate long treks to collect water and free women to pursue income-generating activities. Latrines are particularly important to females for privacy and protection.

4. Reduce Child Mortality. WASHED programs could play a major part in achieving the UN target of reducing by two-thirds the mortality rate among children under five. The UN's statistics are appalling:

- Eleven million children below age five still die every year from preventable causes – about 30,000 a day.
- In low-income countries, one out of every 10 children dies before the age of five. In wealthier nations, this number is only one out of 143.

5. Improve Maternal Health. The UN says: "... in sub-Saharan Africa, women have a one in 16 chance of dying in childbirth. In low-fertility countries in Europe, this number is one in 2,000 and in North America it's one in 3,500." WASHED programs could help by providing increased access to safe water. Improved sanitary and hygienic conditions, along with a reduced distance water that must be carried, would reduce the maternal mortality ratio.

6. Combat HIV/AIDS, Malaria and other diseases. Although the UN's primary targets are AIDS and malaria, WASHED programs would help the survival rates of people with diseases. A person with a compromised immune system is at greater risk when drinking unsafe water. Typhoid and cholera incidence can be dramatically reduced by provision of safe drinking water and sanitary conditions. Parasites like Guinea worms can be eliminated from drinking water with biosand filters. The incidence rate of river blindness can be reduced with more accessible safe water and better hygiene.

7. Ensure Environmental Sustainability. One target of this UN goal is to reduce by half the proportion of people (approximately 1 billion) without sustainable access to safe drinking water. Another target is to improve the lives of at least 100 million slum dwellers, by 2020.

The oil industry has been widely criticized for damage to the environment. This is an opportunity to develop a positive environmental image by correcting disastrous situations that were not caused by energy activities. WASHED programs guided by petroleum resources could mitigate the disasters that exist in slums and rivers throughout the world.

Teaching the use of latrines to block fecal-oral disease paths and use of composting latrines to provide fertilizer for improved crop yields would have a big impact. Subsidized biosand filters, accompanied by a requirement to demonstrate good hygiene and sanitation, are an inexpensive solution now employed by one of Lifewater's indigenous partners. See Appendix 1 for a description of a biosand filter.

8. Develop a Global Partnership for Development. A WASHED program would dramatically improve the health of a community. In turn, healthier people are more productive. Hutton and Haller's UN report indicates that the return on \$1 invested in water and sanitation improvements in a developing country creates an economic return ranging from \$5 to \$28⁹. The recent emergence of India's and China's economies show that an improved economy increases demand for petroleum products; so this is a win-win situation.

Oil & WASHED are a logical fit.

The skills required for WASHED programs are a logical fit for petroleum engineers as well as other members of our industry. Former SPE president, Lyn Arcsott stated that hydrology, drilling, pump repair, and water filtration, are a natural fit for SPE members' skills¹⁰. Coupling hygiene and sanitation training programs with safe water would make the water programs more effective and demonstrate to the world that we are having a significant positive on the environment.

It is well known that "an ounce of prevention is worth a pound of cure." Just as WASHED eliminates many of the issues that cause disease, death, and poverty, a focused WASHED effort by industry could profoundly show the world that we care about mankind. It would demonstrate that the oil industry has priorities other than generating wealth.

Charitable efforts by the oil industry go largely unnoticed because there is no focus. If WASHED were to become the "signature" charity of the oil industry, the public would better appreciate our role. The signature of the Gates Foundation is global health. If the world were to see the oil industry as possibly the biggest player in solving the underlying causes of the world's eight biggest problems, it could dramatically and significantly improve our image.

The competitive nature of our industry might appear to be a major hurdle, but individual companies could identify countries or communities where they want to work and partner with a small NGO to do that. Publicizing the effort on a worldwide scale could potentially occur through a new non-profit organization founded by SPE president Abdul-Jaleel Khalifa and others. This organization, titled Industry's Humanitarian Support Alliance NGO (IHSAN) can be found on the worldwide web at www.IHSAN-H2O.org.

Lessons from the Field

Many lessons were learned by the author of this paper from volunteer trips with Lifewater to Tibet, Ethiopia, Uganda, and Zambia. Although every situation is unique, experiences and observations from these trips should be beneficial to petroleum engineers intend get involved and make a difference. The blog www.WASHEthechildren.blogspot.com contains pictures and more information about these trips.

Personal Health and Comfort. It is a common reaction to become stressed when in unfamiliar situations. An experienced NGO knows that volunteers' experiences must be favorable, or it is unlikely they will volunteer again. This is also important to the indigenous partner who depends on

further funding and support. They provide for the comfort and safety of volunteers while in country with good planning. An experienced NGO will provide packing lists, immunization guidance, reliable partners, and common sense tips like eating only cooked foods. One of several water purification devices that are available should be packed in the event that bottled water is not accessible. Mosquito nets are essential in countries where malaria is prevalent. Discreet use of hand sanitizers is advisable after shaking hands with persons whose hygiene habits are likely to be poor.

Safety. Although the NGO and the indigenous partner will be very careful to provide for the volunteers' personal safety, it is prudent to personally check their government's travel advisories and other sites. The situation in each of the four countries appeared to have been exaggerated by media and websites. Historically, the biggest safety issue in developing countries has been vehicle accidents. Tires are often bald, and roads are often very poorly maintained.

Safety precautions for the indigenous workers were typically unacceptable by oil industry standards. For example, some of the indigenous students wore "flip-flops." A discussion of this in one country revealed that personal protective gear is not subsidized. Further, an injured worker's income is likely to evaporate because there is no legal or insurance protection. Lack of funds and lack of regulations in these countries are causes of this situation, but we could teach safety concepts.

Training Techniques. A valuable lesson from teaching in a developing country is that the teaching technique must be adapted to both empower the students and assure sustainable, desired project results. The technical aspects of drilling a water well or repairing a pump are just one part of the necessary training. Trainers must also identify barriers like cultural issues that could prevent a project from succeeding.

Lifewater teaches that there are six community assets that must be understood:

- Human – skills, health, knowledge
- Social – political structure, networks
- Natural – local environment, climate, flora, fauna
- Physical – man-made infrastructure like transport
- Economic – money, livestock, tools
- Spiritual – beliefs, faith

Failure to incorporate knowledge of the community or obtain their buy-in can completely incapacitate a project. Community members may lack education, but they know their politics, religion, culture, weather patterns, and other factors that must be considered. Sustainable projects require effective promotion – especially with sanitation and hygiene. A community must be convinced that they need to change their hygiene and sanitation habits, so promotion is an essential component of training. For example, it is not easy to persuade a family to use water that was gathered at considerable effort for the purpose of washing hands.

According to WHO: *Telling poor people what to do, telling*

them "what's good for them", does not work¹¹. Experienced NGOs have developed a style that works best for them. Lifewater has developed a participatory teaching style that encourages people to learn problem solving skills. Skits, drawings, community mapping, small group discussions, and other techniques are beneficial both for learning situations unique to a community and culture and for reinforcing the material for the students who then must employ these same teaching techniques in the communities.

When the NGO volunteers return to their homes or jobs, the indigenous team, which may be comprised of people with educations varying from a couple years of basic school to advanced degrees, must be able to function. Each of the four Lifewater trips consisted of about a week of training students employed by the indigenous partner followed by another week of observing those students working in a village. The partner provided interpreters in two of the countries where it was necessary.

Sanitation and Hygiene. Walking through slums and rural villages leaves a lasting impression. Human feces on the ground, flies covering food, and piles of trash are critical problems that can be corrected at relatively little cost. Watching long lines of villagers waiting to collect water and streams of women walking along the roads with jerry cans to be filled in a slough makes the importance of accessible water very clear.

Without incorporating safe water, sanitation and hygiene into community practices, efforts to improve health may fail. Lifewater and its partners teach the importance of a holistic approach. One recent approach is to require a community to demonstrate good hygiene and sanitation practices prior to receiving subsidized safe water.

Lifewater volunteers teach indigenous partners the importance of blocking disease paths. Bacteria from uncovered feces and garbage can be transmitted through the mouth from contact with water, flies, hands, and food. Hygiene and sanitation practices can block those disease paths. Latrines, landfills, and hand washing are essential practices that can enable safe drinking water to reduce disease.

Contamination of major rivers like the Amazon, Ganges, Mekong, Nile, Yangste, and Zambezi spread disease and reduce important sources of food. This can be prevented with improved sanitation and environmental protection. The oil industry can have a powerful positive impact on the world's environment – more than offsetting the damage of the occasional oil spills – by teaching communities to stop contributing to the monumental environmental disaster caused by contaminating their own sources of safe water.

Schools. Schools are a logical, cost-effective place to fund WASHED programs. We visited schools and met with administrators on three of the trips. Some schools form health clubs to reinforce healthy habits. Older children teach these concepts to younger children and even their parents.

Incorrectly constructed latrines were the rule rather than the exception. A properly constructed and maintained Ventilated Improved Pit (VIP) latrine will control smells and flies. It was very apparent that the school administrators were not aware of the deficiencies. The concept of composting appeared to be a significant cultural hurdle when that option was discussed with a school's headmaster.

Adequate water for hand washing and especially soap must be provided at schools to create a model that will influence the children and their communities.

Simplicity. Even drilling rigs are simple to operate. The rig in figure 1 is an example of the small size and simplicity of one of the rotary drilling rigs used by WASH NGOs. The LS-200 is capable of drilling in 200 feet of dirt or clay. Other rigs, like cable tools, may be more appropriate in some locations.

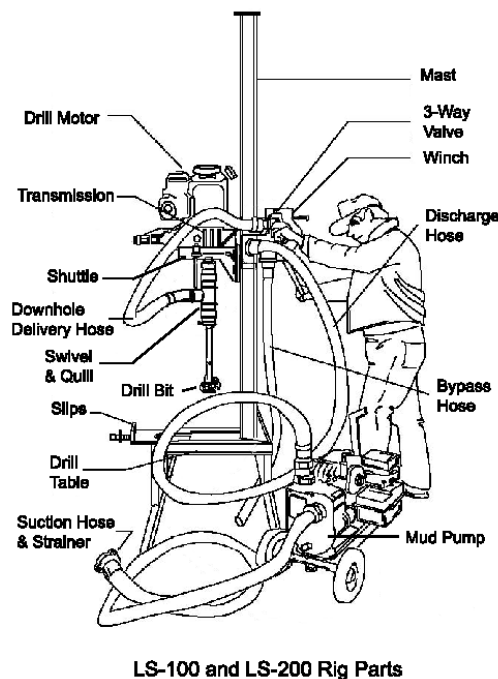

LS-100 and LS-200 Rig Parts

Figure 1. (reproduced courtesy of Lifewater International.)

Simple solutions usually work better in developing countries. In Ethiopia, a village leader was pleased that our indigenous partner was replacing a progressive cavity pump with a hand pump. He indicated that women were having an unusually high number of miscarriages, which he believed these were attributable to difficulty turning the pump handle.

Many organizations have made the mistake of providing technology they view to be best for a particular region. Pump seals often fail within a few months of completing a well. Unless there is an indigenous team trained and equipped to repair that particular type of pump, it may never be repaired. As result, equipment that can be found in most parts of the world, like the India Mark II hand pump (figure 2), have become the standard of many NGOs and even governments.

There are a number of reasons that experienced NGOs avoid

high tech solutions like solar powered pumps. Repair capabilities and equipment parts are not likely to be available outside of large cities. It is better to install equipment that is not easily stolen – and of little value if it is. Equipment that may be in more or less constant use must be durable because community members may not understand equipment limitations.

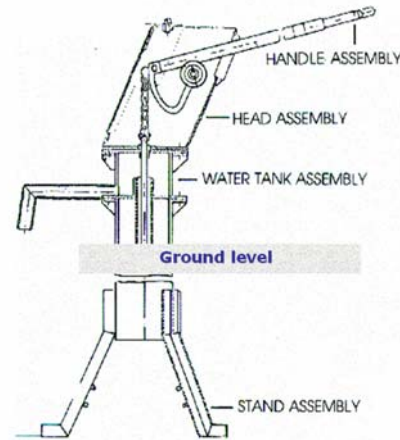

Figure 2. India Mark II hand pump

Seven keys to an Effective WASHED program

Although WASHED technologies are simple, the efforts necessary to share them with developing communities are not. Lifewater training and volunteer trips have made it clear that there are some essential elements of a successful program. On one of the trips, it became clear that the indigenous people appreciate training organizations that are truly committed.

1. All WASH components must be included. Failure to include sanitation and hygiene with a safe water program would seriously compromise the outcome. Promoting hygiene and sanitation concepts is inexpensive yet crucial to a successful water program. The benefits of a visit by medical teams would be short lived if safe water or sanitation and hygiene practices are not in place to eliminate the root cause of most of the illnesses.

2. Education (prevention vs. reaction). People will not change their habits if they don't understand that there is a problem. Jenkins reports that communities often do not include health benefits as one of the top five reasons for using latrines¹². To them, seemingly trite solutions like making their life "more modern" or "avoiding embarrassment" may be the most compelling reasons to improve their health practices.

Schools are an obvious place to teach WASH concepts. Health clubs in schools are an inexpensive, yet effective promotional technique. In these clubs, older children teach younger children. Responsibilities, like latrine maintenance, are shared. Just a little funding of school clubs has a powerful impact.

3. Development (sustainability). For a developing country to become self sufficient, its people must learn to handle manageable problems like WASH issues without foreign assistance. It is far more empowering and inspiring for a

community to see persons from their country, rather than foreigners, repairing or drilling a well, so it is important to stay in the background when observing students in communities applying what they have been taught.

Relief efforts in the absence of an emergency create dependency. A Chinese proverb says: “Give a man a fish, and you feed him for one day. Teach a man to fish, and you feed him for a lifetime.” Developing countries need the means to continue the work indefinitely after volunteers and aid workers depart. When communities observe improved health and living conditions of family groups that have received a biosand filter, they are willing to pay for a biosand filter of their own.

4. Time-tested, focused NGOs. Engineers are taught: “don’t reinvent the wheel.” NGOs that have survived the test of time have developed policies and procedures, contacts, an accountability process, safety screening, training programs, and other processes that are WASHED program necessities. Proper focus is important, because the NGO must not get sidetracked outside its expertise or attempt to provide too much information in one trip. If the WASHED components are just one of the things an NGO does, rather than their primary focus, they may not be the best choice. Reasonable overhead charges are another attribute of a good NGO.

Wooster cites histories of large, powerful foundations whose “arrogance” actually hurt the cause they were trying to help¹³. Volunteers and companies working with a variety of time-tested NGOs would provide far more exposure and have more impact than would a single, powerful foundation with great resources. Organizations like the Millennium Water Alliance www.mwawater.org can steer donors and volunteers to appropriate NGOs.

5. Noble, committed, and efficient indigenous partner. An important function of a good NGO is to locate indigenous partners who have noble objectives and commitment to fulfill them. Those partners and their employees must feel like they are loyal patriots who are called to help their country. They must make sacrifices like working below the wage scale that others begin to offer them once they acquire WASHED skills.

Lifewater’s approach is to train trainers and implementers rather than to have volunteers do the work themselves. These partners understand their local culture, government, and other constraints. They can develop the community rapport, trust, and respect that must exist before a project even begins. These partners can perform the ongoing work that is needed at less cost and with fewer problems than well-meaning NGO volunteers. Probably their most important function is to ultimately carry on the work without outside support. It is a rare indigenous partner that can perform all these functions AND comply with accountability requirements necessary to channel funding to the people who need the most help.

The NGO and the indigenous partner must work well together. Rickett says there are nine “imperatives”¹⁴

- Creating shared vision

- Establishing compatibility
- Applying ground rules
- Identifying alliance champions to make it work
- Building intercultural understanding
- Fostering mutual trust
- Measuring progress and meaningful results
- Documenting agreements, contributions, & outcomes
- Learning and handling change together.

It is important to understand the social and cultural issues of a community. Maranz states that one of the most fundamental economic considerations in the majority of African societies is the distribution of economic resources so that all persons may have their minimum needs met, or at least that they may survive¹⁵. Accordingly, indigenous partners must be willing and able to provide documentation and accountability for their projects.

6. Community-based program/ownership. People take care of assets when they have some level of ownership. When a program first begins in a community, it may be difficult for them to financially participate in a project. They can provide “sweat equity” by performing manual labor functions like digging and clearing weeds. Communities must understand the necessity of proper maintenance and maintaining a repair fund. While a multinational company might create a negative response by refusing to work with a community that will not take responsibility, it is easy for an indigenous partner to demand some level of community participation. Lifewater teaches its partners to convince the communities to save funds for future pump repairs when a pump is fixed.

7. Relational/culturally relevant. An important outcome of a WASHED project, aside from the primary benefit of sustainable improved health, is that everyone involved feels good about the project experience. One volunteer with a bad or arrogant attitude can leave such a bad impression that the positive benefits are overshadowed.

Religious and spiritual beliefs, if consistent with those of the trainers, can also have a powerful influence, because communities will more readily embrace something consistent with their belief system. For example, in a Christian community, Lifewater’s volunteers and indigenous partners would teach that God commands good sanitation and hygiene in the Bible: *Designate a place outside the camp where you can go to relieve yourself. As part of your equipment have something to dig with, and when you relieve yourself, dig a hole and cover up your excrement.* (Deuteronomy 23:1-3).

From “Success” to “Significance” and Respect

“Success” is a word that describes self gratification like winning a sporting event, graduating from school, getting a promotion, and of course, attaining wealth. Most engineers have achieved a large measure of success compared to most people in the world. Respect is not a logical byproduct of success in the world today. A petroleum engineer’s success is of no benefit to an impoverished child that receives no assistance. People who are victims of their circumstances

often resent people and businesses that are successful. "Significance" may be defined as having a special meaning, or as having considerable influence or effect on others. It goes beyond personal fulfillment. People who feel insignificant may suffer job dissatisfaction or clinical depression anxiety. Public perception of the oil industry is that our companies care only about financial success. The reputation of an industry is typically a function of an organization's values, which are reflected in the way it conducts business, treats its employees, and what it gives back to the community – not merely its financial success.

Companies: Companies are more profitable and people are more loyal to a company that provides them a sense of worth. Our industry and companies within it should avoid building a bureaucracy to improve its image. One benefit of working with numerous NGOs and partners is that it would maximize the number of people, agencies, and governments that are aware of a company's oil WASHED efforts. An industry group like IHSAN could possibly serve WASHED efforts by providing statistics, pictures, and success stories (for publicity) from individual companies that choose to become involved.

SPE Foundation President Roy Koerner stated that psychologists have demonstrated that helping others less fortunate provides a sense of well-being and enrichment by showing that we lead a purposeful life¹⁶. The oil industry could make WASHED projects its "signature" and be welcomed to communities with well-deserved respect.

Life Satisfaction. Job satisfaction has indisputable benefits that provide a temporary sense of purpose, but fulfilling a truly worthwhile purpose will provide "life satisfaction." Once a person becomes "successful", it becomes a matter of choice whether to become "significant." Petroleum engineers and other members of our industry can fulfill this greater purpose - and reap its rewards -- by getting involved. Gist says that knowledge and skills contribute to leader effectiveness, but impact comes from a leader's inner development and outreach¹⁷. True leaders are those who can see past personal success to help others achieve success, too.

Personal involvement and experience as a volunteer is the most rewarding step. Personally helping to improve the living conditions of impoverished children is immensely gratifying and significant. For those whose situation will not allow this sort of activity, another valuable function is to mobilize resources. Companies are more likely to respond if an employee raises awareness. Another untapped resource is the retired workforce. Engineering skills make it easier to teach drilling, pump repair, and water filtration, but recruiting volunteers should not be limited to engineers, because these technologies are so basic that they can be learned in a matter of days. The need is overwhelming, so there will be no surplus of volunteers. Persons and companies who want to get involved should contact safewater@spe.org , www.IHSAN-H2O.org or one of the various WASH NGOs.

Our age of luxury and abundance exists in part from the effort, brilliance, and faculty of the oil industry. For many

complicated reasons, this success comes with a tag of unfavorable public opinion. Yet, now the opportunity to shift the way the world perceives the oil industry's prosperity stands before us. We can reap the rewards of personal fulfillment and an improved image by transforming despairing peoples to changed civilizations with purpose, promise, and hope.

Helen Keller once said: *Many people have a wrong idea of what constitutes true happiness. It is not attained through self-gratification, but through fidelity to a worthy purpose.* What greater legacy can a person or a company leave than to save the lives of innocent, helpless children and provide them a healthy future? That is "significance."

Acknowledgements:

The support and encouragement of SPE Presidents Abdul-Jaleel Al-Kalifa, Roy Koerner, and Lyn Arscott and their sincere desire to guide the oil industry to improving its image with a focused WASHED effort has been inspirational. The decades of unselfish work and vision of the Lifewater staff and volunteers helped me recognize this higher purpose for the oil industry. Jim Frazier and Mitch Meyer of Fidelity E&P have been remarkably supportive. Most of all, the courageous fight with cancer by my deceased wife, Karen, which led me to realize this higher purpose, and the incredible encouragement and support of my wife, Susan, have been invaluable.

References

1. Financial Times, *Big Oil drills for Vote of Approval* 26 July 2007 downloaded 28 Jul 2007
2. Porter, M.E. and Kramer, M.R.; *Strategy & Society the Link Between Competitive Advantage and corporate Social Responsibility*, Harvard Business Review. downloaded from www.HBR.org on Oct 2007.
3. Al-Kalifa, A.J. *People First: Global Mission*. JPT March 2007: 10-12 .
4. Engardio, P. *Beyond the Green Corporation*. Business Week, 29 January 2007: 52.
5. Medilyn <http://www.undp.org/mdg/goal5.shtmly>. downloaded Oct 2007
6. BBC News *Sanitation 'best medical advance'* 18 January 2007 downloaded Oct 2007
7. WaterAid, downloaded from www.wateraid.org.uk/site/what_we_do/how_we_work/statistics/default.asp, Oct 2007.
8. United Nations, <http://www.un.org/millenniumgoals/> downloaded Oct 2007.
9. Hutton G. & Haller L. *The Costs and Benefits of Water and Sanitation Improvements at the Global Level* (WHO 2004)
10. Arscott, L. *Drilling for Water and Life – the Human Side of Petroleum Engineering*, JPT April, 2007: 22-24.
11. World Health Day Report. downloaded Nov 07 from http://www.who.int/water_sanitation_health/takingcharge.html
12. Jenkins, M. *Who Buys Latrines, Where and Why?* 2004.
13. Wooster, M.M. "Great Philanthropic Mistakes" Bradley Center for Philanthropy and Civic Renewal Hudson Institute Washington DC 2006:156
14. Rickett, D. *Making Your Partnerships Work*. Winepress Publishing. Enumclaw WA, 2002: 25
15. Maranz, D.E., *African Friends and Money Matters*, SIL International, Dallas, 2001, 4-5.

16. Koerner, R.H., *Safe Drinking Water: A Case for Service*. JPT May 2007: 22-24.
17. Gist, Marilyn, *Leading: from Success to Significance*, Post-Intelligencer, downloaded October 2007.

Appendix 1: Biosand filter

This slow sand filter, developed by Dr. D. Manz at the University of Calgary, is a technology being widely embraced around the world by NGOs engaged in WASH projects. Supported by the Centre for Affordable Water and Sanitation Technology (CAWST), a biosand filter can remove about 99% of bacteria, viruses, and all worms when used properly. The mechanisms involved are physical straining, predation by “good bacteria”, and die off. See www.CAWST.org for more information.

The biosand filter can be constructed from readily available, low cost materials like cement, sand, and gravel at a cost that is affordable even in developing countries. It is designed for intermittent use by small numbers of people. Seeds of Hope International Partnership, an indigenous group in Zambia trained by Lifewater and CAWST, has developed a solution for highly populated communities with WASH problems. They provide a subsidized biosand filter to persons who have demonstrated that they are employing lessons of hygiene and sanitation training that they have received

It is not critical to eliminate pathogens. Biosand filters reduce bacteria populations to levels that are tolerable to people in developing countries. When the filters are improperly used, bacteria populations are not reduced as significantly. However, even a 90% reduction may be sufficient if proper hygiene and sanitation practices are in place.

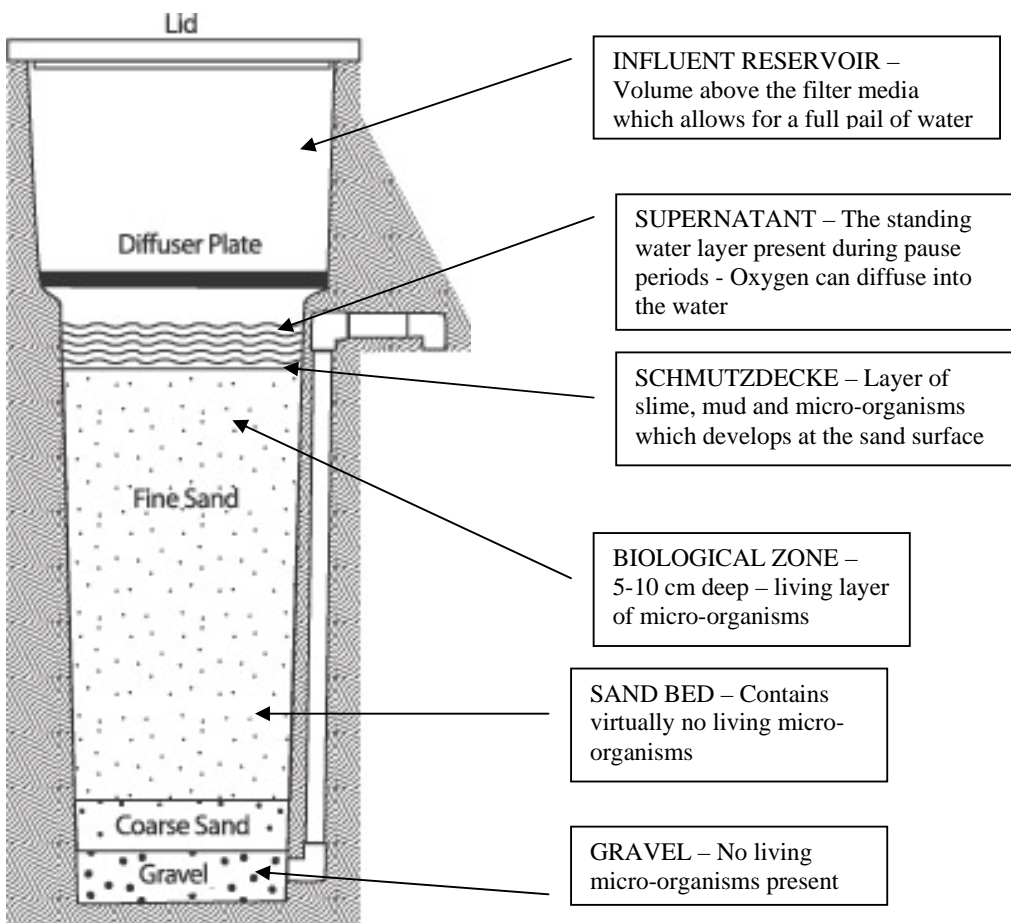

Figure 1 Bio-sand filter - reproduced by permission of the Centre for Affordable Water & Sanitation Technology.